

S-Band Radar Pallet

Part number IB2729M300 is a 50 Ω matched high power pulsed radar pallet amplifier for S-Band radar systems operating over the instantaneous bandwidth of 2.7-2.9 GHz. The pallet amplifier supplies a minimum of 300 watts of peak pulse power under the conditions of 100 μ s pulse width and 10% duty cycle. All devices are 100% screened for large signal RF parameters.

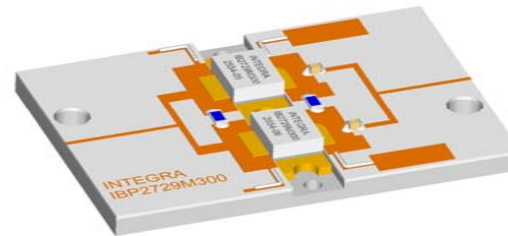

Silicon Bipolar

- Ultra-high f_T

Class C Operation

- High Efficiency

Common Base Configuration

- Single Power Supply

Gold Metal

- Maximum Reliability

Emitter Ballasting

- Optimum Thermal Distribution

Internal Impedance Matching

- Ease of Use
- Ultra-low Loss Design

Be0 Package

- Unmatched Thermal Reliability

RF Test Fixture

- Broadband
- Matched to 50 Ω
- Long-term Correlation
- 100% Device RF Screening
- No External Tuning Allowed
- Micro-strip structure on soft pc board with dielectric constant 10.2

TYPICAL DATA

TYPICAL DATA

TYPICAL DATA

TYPICAL DATA

Device	Freq (MHz)	V _{CC} (V)	P _{IN} (W)	IRL (dB)	P _{OUT} (W)	G _p (dB)	I _c (A)	η_c (%)	Droop (dB)
D5548-1	2700	36	45.9	-14	360	9.21	1.87	57.03	-0.27
	2800	36	45.9	-11	306	8.23	2.21	38.45	-0.25
	2900	36	45.9	-16	351	8.84	2.15	45.35	-0.42

MAXIMUM RATINGS

Screen	Parameter	Symbol	Min	Max	Units	Test Conditions
BD	Collector-Emitter Voltage	V_{CES}	--	70	V	$V_{BE}=0V$.
BD	Emitter-Base Voltage	V_{EBO}	--	3.5	V	--
BD	Collector Current, Peak	I_C	--	34.1	A	PW=PW1, DF=DF1.
BD	Continuous Power Dissipation, Peak	P_D	--	1049	W	PW=PW1, DF=DF1, $T_F=25^{\circ}C$.
BD	Storage Temperature Range	T_{STG}	-20	+125	$^{\circ}C$	--
BD	Operating Junction Temperature Range					
Note	Screen 'BD' = parameter qualified By Design.					

THERMAL CHARACTERISTICS

Screen	Parameter	Symbol	Min	Max	Units	Test Conditions
BD	Thermal Resistance per Device	$R_{TH(JC)}$	--	0.30	$^{\circ}C/W$	$V_{CC}=V1$, PW=PW1, DF=DF1, $T_F=25\pm 5^{\circ}C$, $P_{OUT}= 300W$
Note	Screen 'BD' = parameter qualified By Design.					

PROCESSING SPECIFICATIONS

Screen	Parameter	Symbol	Min	Max	Units	Test Conditions
100%	DC Wafer Probe	--	--	--	--	Per Integra specification.
Q1	Wafer DC and RF Qualification	--	--	--	--	Per Integra specification.
LM	Wire Bond Strength	--	--	--	--	Line monitor per Integra specification.
100%	Pre-cap visual inspection	--	--	--	--	Per Integra specification.
100%	Gross leak test	--	--	--	--	MIL-STD-750D, Method 1071.6, Test Condition C.
Note	Screen 'Q1' = parameter is qualified by assembly and test of 3 pieces minimum per wafer.					
Note	Screen 'LM' = parameter is qualified by assembly line monitor.					

RF ELECTRICAL CHARACTERISTICS

Screen	Parameter	Symbol	Min	Max	Units	Test Conditions
100%	Input Return Loss	IRL	10	--	dB	$V_{CC}=V1, PW=PW1, DF=DF1, T_F=25\pm5^\circ C, P_{OUT}=300W, F=F1, F2, F3.$
100%	Input Power	P_{IN}	--	53.3	W	$V_{CC}=V1, PW=PW1, DF=DF1, T_F=25\pm5^\circ C, P_{OUT}=300W, F=F1, F2, F3.$
100%	Power Gain	G_P	7.5	--	dB	$V_{CC}=V1, PW=PW1, DF=DF1, T_F=25\pm5^\circ C, P_{OUT}=300W, F=F1, F2, F3.$
100%	Collector Efficiency ($P_o/I_c/V_{CC}$)	N_C	35	--	%	$V_{CC}=V1, PW=PW1, DF=DF1, T_F=25\pm5^\circ C, P_{OUT}=300W, F=F1, F2, F3.$
100%	Pulse Amplitude Droop	D	--	1.0	dB	$V_{CC}=V1, PW=PW1, DF=DF1, T_F=25\pm5^\circ C, P_{OUT}=300W, F=F1, F2, F3.$
100%	Gain Flatness	GF	--	1.3dB	dB	Calculate from min/max gains at frequencies F1, F2 and F3.
100%	Delta Insertion Phase Variation	d-IP	-20	+20	Deg	$V_{CC}=V1, PW=PW1, DF=DF1, T_F=25\pm5^\circ C, P_{OUT}=300W, F=F1, F2, F3.$
100%	Stability into 1.5:1 VSWR	VSWR-S	--	--	--	$V_{CC}=V1, PW=PW1, DF=DF1, T_F=25\pm5^\circ C, P_{OUT}=300W, F=F1, F2, F3.$ Rotate 1.5:1 output VSWR through 360° phase. No oscillatory or pulse break-up characteristics allowed on detected output pulse. All non-harmonically related signals must be at least -50 dBc.
100%	Stability with + 1dB Input Power Overdrive	OD-S	--	--	--	$V_{CC}=V1, PW=PW1, DF=DF1, T_F=25\pm5^\circ C, P_{IN}=(P_{IN}@P_{OUT}=300W)+1dB, F=F1, F2, F3.$ No oscillatory or pulse break-up characteristics allowed on detected output pulse.
Note	V1 = 36V; PW1 = 100µs; DF1 = 10%; F1 = 2.70 GHz, F2 = 2.80 GHz, F3 = 2.90 GHz.					
Note	T_F = Device flange temperature.					
Note	Screen 'BD' = parameter qualified By Design.					

PALLET DIMENSIONAL OUTLINE DRAWING

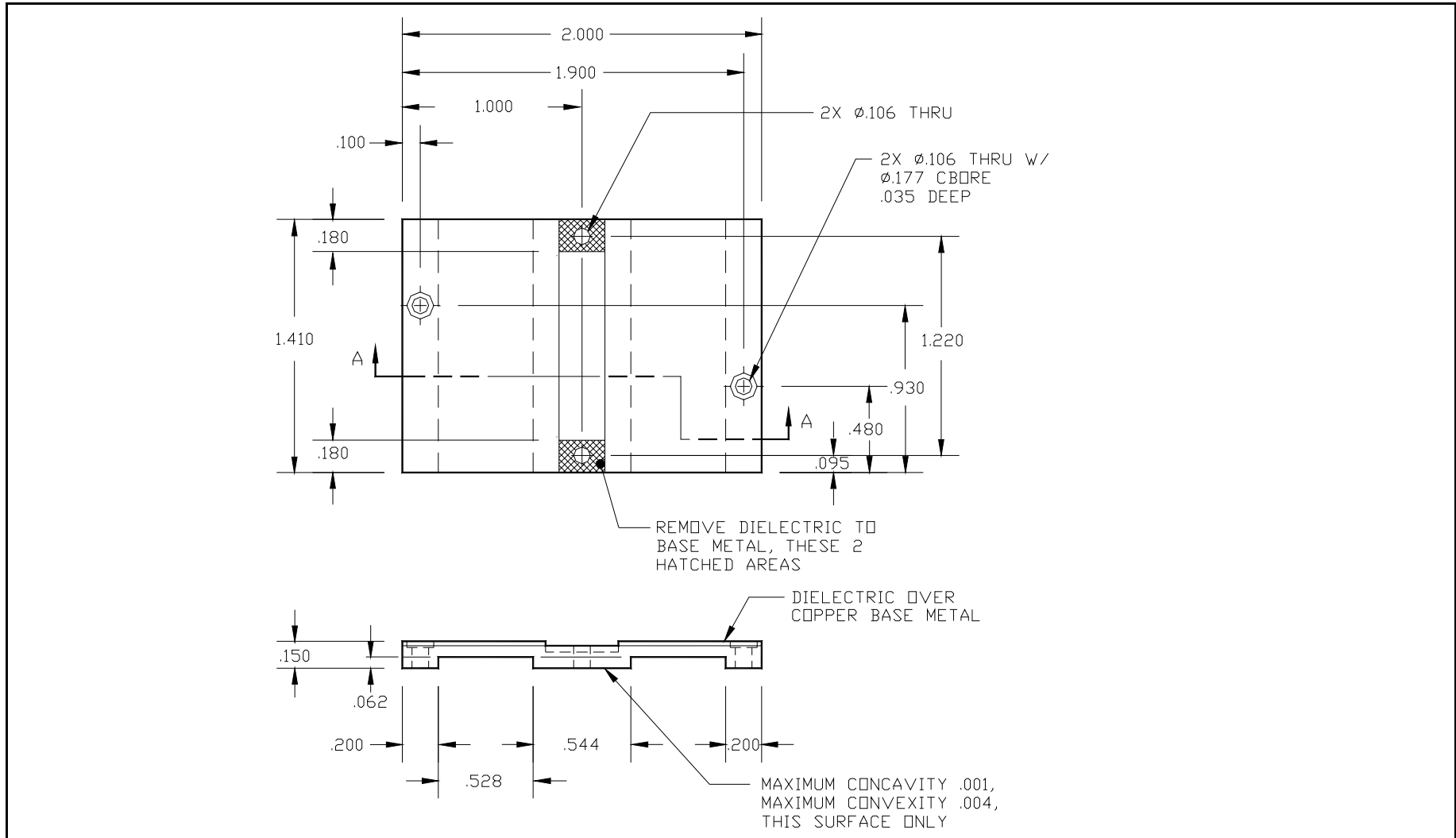

50Ω RF TEST FIXTURE

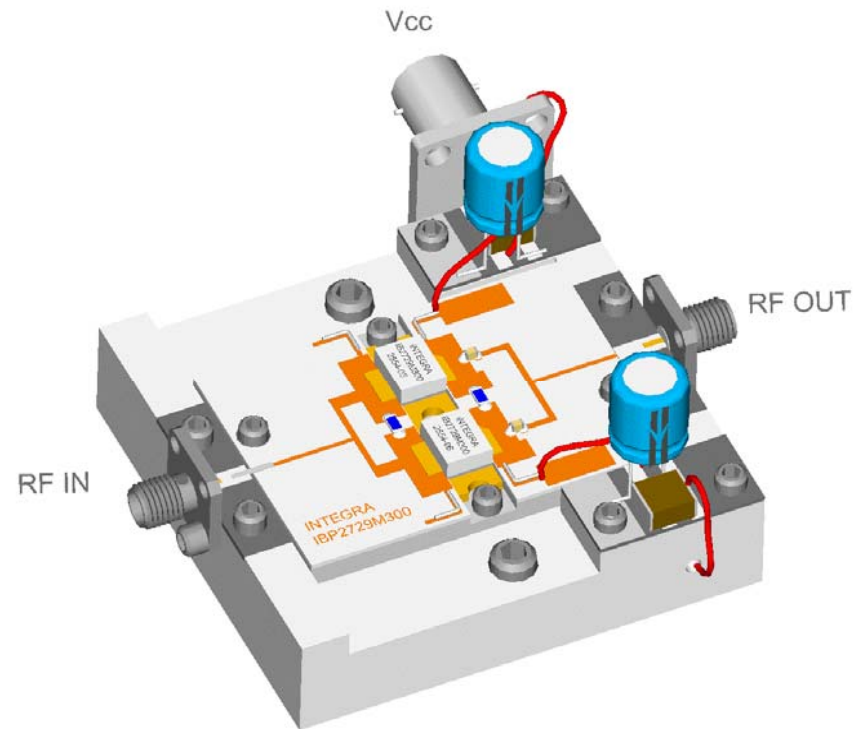

Data Sheet Status	
Proposed Specification	This data sheet contains proposed specifications.
Preliminary Specification	This data sheet contains specifications based on preliminary measurements and data.
Product Specification	This data sheet contains final product specifications.
Maximum Ratings	
Stress above one or more of the maximum ratings may cause permanent damage to the device. These are maximum ratings only. Operation of the device at these or at any other conditions above those given in the characteristics sections of the specification is not implied. Exposure to maximum values for extended periods of time may affect device reliability.	

WARNING

Product and environmental safety - toxic materials
This product contains beryllium oxide. The product is entirely safe provided that the BeO base is not damaged. All persons who handle, use or dispose of this product should be aware of its nature and of the necessary safety precautions. After use, dispose of as chemical or special waste according to the regulations applying at the location of the user. It must never be thrown out with general or domestic waste.

DISCLAIMER

Integra Technologies Inc. reserves the right to make changes without further notice to any products herein. Integra Technologies Inc. makes no warranty, representation or guarantee regarding the suitability of its products for any particular purpose, nor does Integra Technologies Inc. assume any liability arising out of the application or use of any product or circuit, and specifically disclaims any and all liability, including without limitation consequential or incidental damages. Integra Technologies Inc. products are not designed for use in life support appliances, devices, or systems where malfunction of these products can reasonably be expected to result in personal injury. Integra Technologies Inc. customers using or selling these products for use in such applications do so at their own risk and agree to fully indemnify Integra Technologies Inc. for any damages resulting from such improper use or sale.
--